

60 & 80
600/800 kg



Call for Yanmar solutions



TECHNICAL SPECIFICATIONS

60/80 Series

60 serie

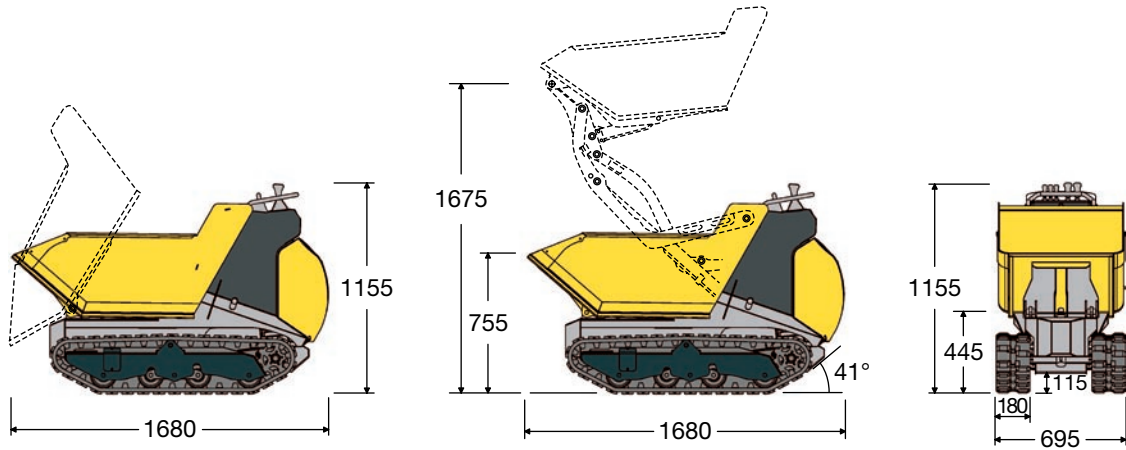

80 serie

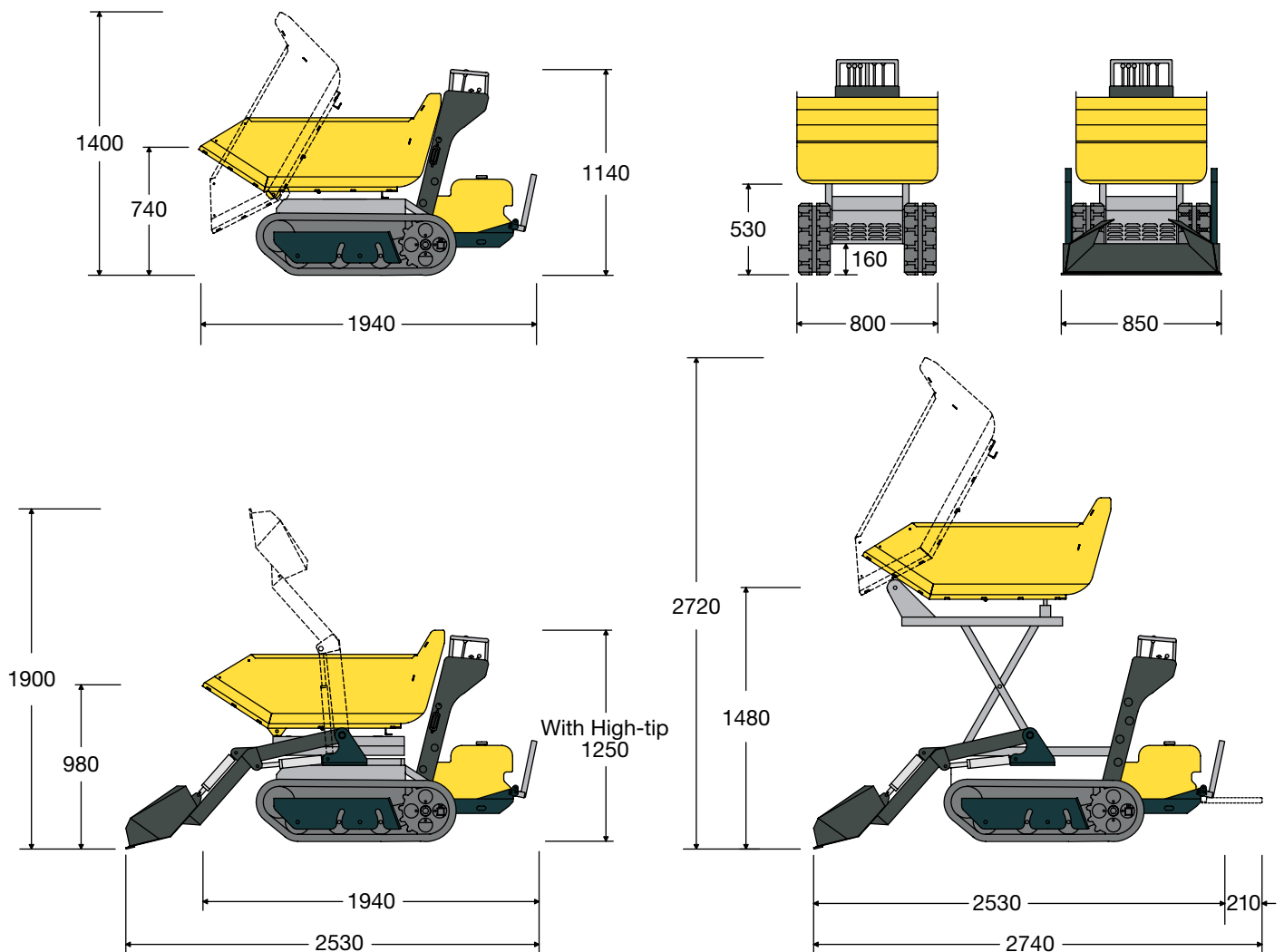

COMPACT AND POWERFUL

The new line of micro- and mini-dumpers « Powered by Yanmar » ideally suited for landscaping and horticultural applications as well as construction sites.

The 60 series has an operating load of 600 kg and is available in two versions: Standard (415 kg) and High-Tip (535 kg). The 80 series, with its operating load of 800 kg, is also available in Standard (500 kg) and High-Tip (600 kg) and can be provided with an optional self-loading system (Standard and High-Tip). The High-Tip models have a discharge height of up to 1,675 mm and are able to tip their payload into most skips, over garden walls and fences and on to raised working levels.

All these models combine high performance, absolute reliability and great compactness. The dimensions of the 60 and 80 series allow them to work in very confined areas where their width (respectively 695 and 800 mm in standard version) can be a real operating bonus. They are also equipped with a very strong tracked undercarriage able to climb stairs or to

operate on difficult soft ground or through snow. The rocking roller design smoothes the passage of the machine over rough areas allowing the load to remain securely in the skip. The 60 & 80 are built to transport all types of building materials and are also suited for the disposal of soil, aggregates and turf.

Micro- and mini-dumpers « Powered by Yanmar » are powered by new Yanmar diesel engines (LA70 7.5hp and LN 100 AE 10hp). They are equipped with an excellent hydrostatic transmission based on pumps with axial pistons and variable flow. This system can provide the specific combination of speed and power needed by the operator. The hydraulic systems for the services and for transmission are separated thus enabling to use the loading functions while travelling. 60 series and 80 series have a top travel speed of 3.6 km/h and 4.8 km/h. The engine hood is solidly attached to the undercarriage and provides optimum servicing and maintenance access through its back cover. The ergonomically designed control panel includes all the switches and levers needed to operate the dumpers.

| | | 60 serie / 600 kg | 80 serie / 800 kg | |
|-----------------------------------|-----------------------------|-----------------------------|--------------------------------|----------|
| Engine | | Yanmar LA70 7.5 hp (Diesel) | Yanmar LN 100 AE 10hp (Diesel) | |
| Transmission | Type | Hydrostatic | Hydrostatic | |
| | Hydraulic pump | 3 x gear pump | 2 x variable displ. pumps | |
| | Flow | 2 x 12 l/mn + 1 x 14 l/mn | 2 x 32.4 l/mn | |
| | Hydraulic motor | 2 x orbital | 2 x orbital | |
| | Brake Parking | | Mechanical | |
| Hydraulic System | Hydraulic pump | Gear pump | Gear pump | |
| | Flow | 1 x 14 l/mn | 1 x 13.5 l/mn | |
| | High-flow | | 1 x 22 l/mn ¹ | |
| | Max pressure | 175 bar | 150 bar | |
| | Main valve Std type | 4 ways | 2 ways | |
| | Oil cooler | Air | Air | |
| | Tipping system | Hydraulic | Hydraulic | |
| Tracks | Standard track width | 180 mm | 180 mm | |
| | Track rollers | 4 | 3 | |
| | Rocking rollers | Yes | Yes | |
| | Track tensioning | Yes | Yes | |
| Performance and dimensions | Max. travel speed | 0 – 3.6 km/h | 0 – 4.8 km/h | |
| | Operating load | 600 kg | 800 kg | |
| | Weight without self-loading | Standard version | 415 kg | 500 kg |
| | | High-tip version | 535 kg | 600 kg |
| | Weight with self-loading | Standard version | | 580 kg |
| | | High-tip version | | 670 kg |
| | Length | Without self-loading | 1,680 mm | 1,940 mm |
| | | With self-loading | | 2,530 mm |
| | Width | Without self-loading | 695 mm | 800 mm |
| | | With self-loading | | 850 mm |
| | Height | 1,155 mm | 1,140 / 1,250 mm | |
| Dumping height | 400 / 1,675 mm | 450 / 1,440 mm | | |
| Tip | | 1,150 x 800 x 350 mm | | |

¹ In option



Printed in France – Materials and specifications are subject to change from the manufacturer without notice – Please contact your local Yanmar Construction Equipment Europe dealer for further information.

Yanmar Construction Equipment Europe S.A.S.

25, rue de la Tambourine
52100 SAINT DIZIER – FRANCE
contact@yanmar.fr

www.yanmar.eu